

PRECISION ELECTRO SPINDLE (Air Cooling)

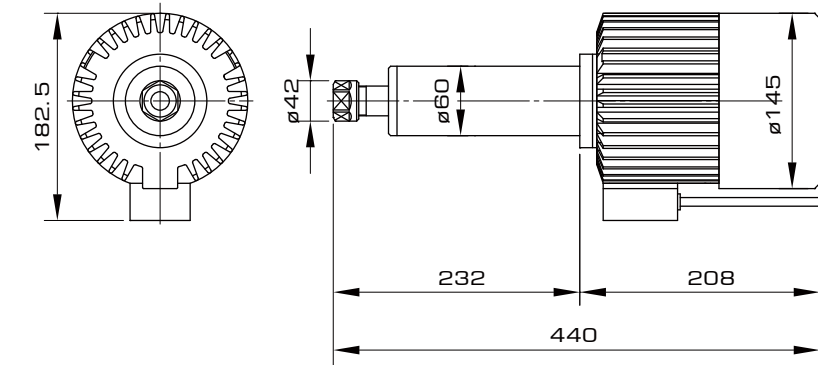

E0623-30

TORQUE AND POWER CURVE

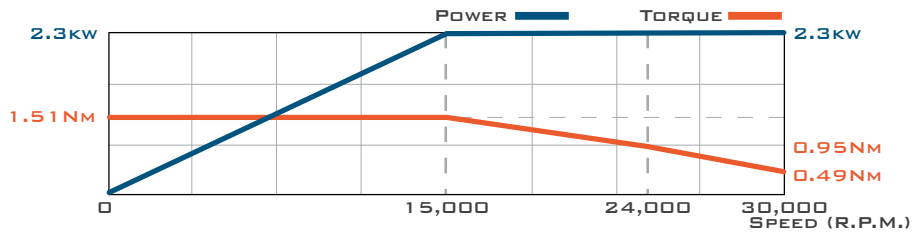

SPECIFICATIONS

項目	內容
安裝方式 Installation Position	立式 / 臥式 Vert / Horiz
轉速 Speed / rpm	7,500~30,000 rpm
頻率 Frequency / Hz	500 Hz
軸承 Ball Type	鋼珠 Steel Ball
軸承潤滑方式 Bearing Lubrication	滑脂 Grease
電壓 Voltage / V	220 / 380 V
功率 Power / KW	2.3 Kw
扭力 Torque / Nm	1.51 Nm
刀把 / 筒夾 Tool Holder / Collet	ER25
刀具夾持柄 Tool dia / mm	Ø1-Ø16
冷卻方式 Cooling Type	風冷 (直結葉片式) Air (Direct Coupled Blade Air Cooling)
主體外徑 D / mm	Ø60 mm
主軸全長 L / mm	440 mm
重量 Weight / Kg	13.5 Kg