

MILLING SPINDLE

With Automatic Tool Change

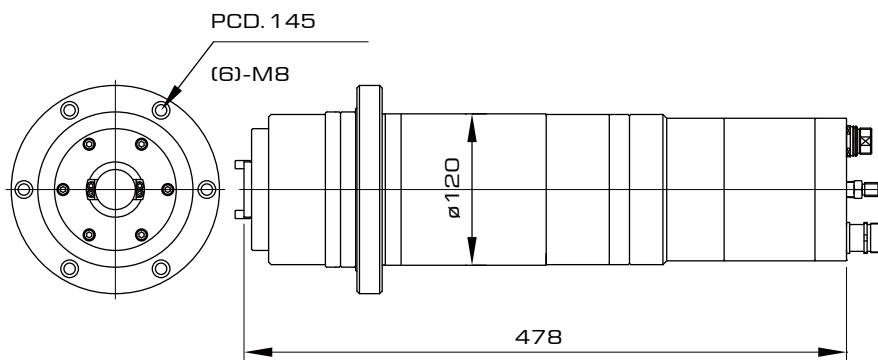

MIA1275-24

TORQUE AND POWER CURVE

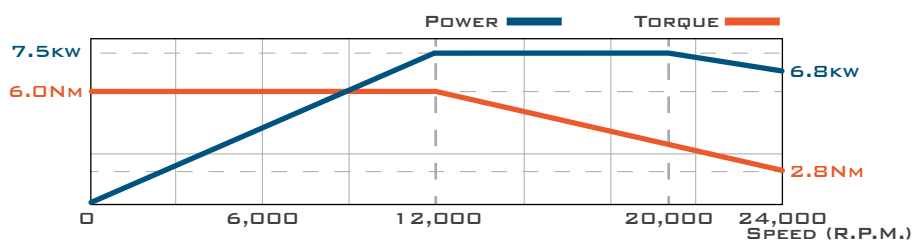

SPECIFICATIONS

項目	內容
安裝方式 Installation Position	立式 / 臥式 Vert / Horiz
轉速 Speed / rpm	6,000~24,000 rpm
頻率 Frequency / Hz	800 Hz
軸承 Ball Type	陶瓷珠 Ceramic Ball
軸承潤滑方式 Bearing Lubrication	滑脂 Grease
電壓 Voltage / V	380 V
功率 Power / KW	7.5 Kw
扭力 Torque / Nm	6.0 Nm
刀把 / 筒夾 Tool Holder / Collet	BT30 / BTT30 / BT30N / HSK40E
冷卻方式 Cooling Type	水冷 Water
主體外徑 D / mm	120 mm
主軸全長 L / mm	478 mm
重量 Weight / Kg	29 Kg