

PFK 高速全圓螺帽刀把

PFK HIGH SPEED COLLET CHUCK WITH ROUND NUT

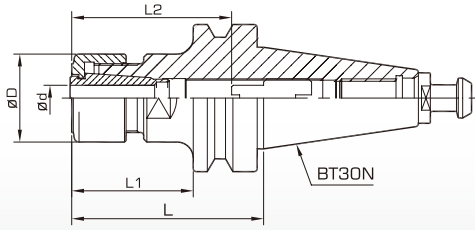

<p>Balancing / 動平衡</p> <p>G6.3 Max.25,000 RPM Or U ≤ 1gmm</p> <p>Option / 選配 G2.5 Max.25,000 RPM Or U ≤ 1gmm</p>	<p>Dimensions / 尺寸標示</p>  
------------------------------------------------------------------------------------------------------------------------------------------------------------------	------------------------------------------------------------------------------------------------------------------------------------------------------------------------------------------------------

Order No. 訂購編號	Range 夾持範圍	øD	L	L1	Tool Clamping Depth L2 刀具夾持深度	page.147	page.144	page.117	page.149	
						Nut 螺帽	Screw 調整螺絲	Collet 筒夾	Wrench 扳手	
BT30N	PFK10-060S	1.75~10.0	27.5	60	38	30~50	CAP-PFK10S	PFK-M12	SK10-P	PHS-10-TW275
	PFK16-060S	2.75~16.0	40	60	38	40~54	CAP-PFK16S	PFK-M18	SK16-P	PHS-20-RO400

Remarks / 備註

- 需配合 3μ P 筒夾 With 3μ P Grade Collet

Applications / 應用



PFK 筒夾刀把

PFK COLLET CHUCK

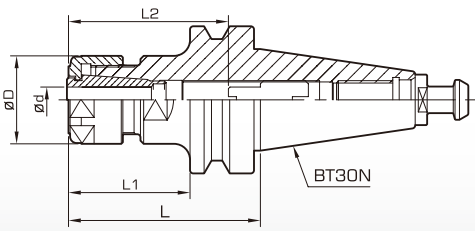

<p>Balancing / 動平衡</p> <p>G6.3 Max.25,000 RPM Or U ≤ 1gmm</p> <p>Option / 選配 G2.5 Max.25,000 RPM Or U ≤ 1gmm</p>	<p>Dimensions / 尺寸標示</p>  
------------------------------------------------------------------------------------------------------------------------------------------------------------------	------------------------------------------------------------------------------------------------------------------------------------------------------------------------------------------------------------

Order No. 訂購編號	Range 夾持範圍	øD	L	L1	Tool Clamping Depth L2 刀具夾持深度	page.147	page.144	page.117	page.148	
						Nut 螺帽	Screw 調整螺絲	Collet 筒夾	Wrench 扳手	
BT30N	PFK10-060	1.75~10.0	27.5	60	38	30~50	CAP-PFK10	PFK-M12	SK10-P	PHS-PFK10
	PFK16-060	2.75~16.0	40	60	38	40~54	CAP-PFK16	PFK-M18	SK16-P	PHS-PFK16

Remarks / 備註

- 需配合 3μ P 筒夾 With 3μ P Grade Collet

Applications / 應用

